

Converts Multi Location Manual to Multi Location Automatic

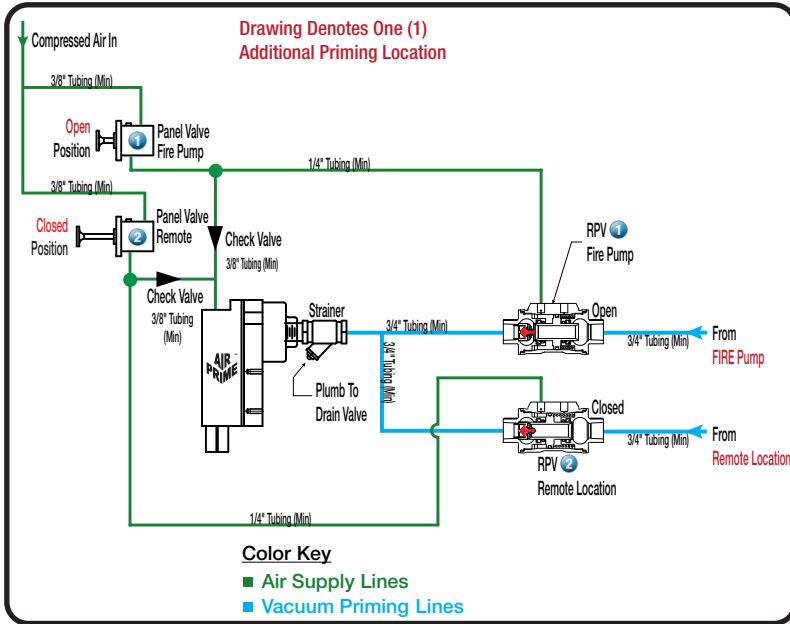

**Figure 1**

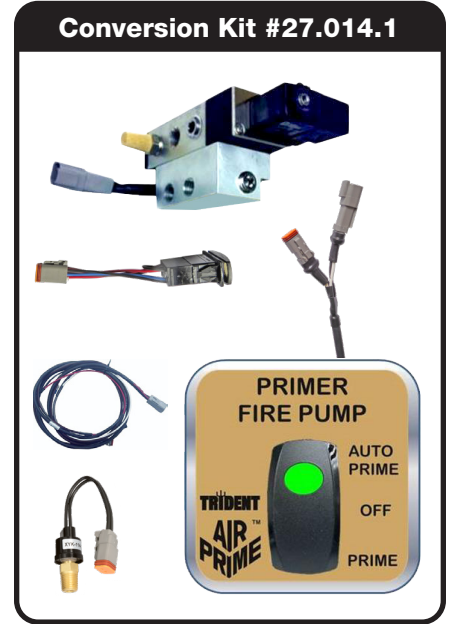

**Figure 2**

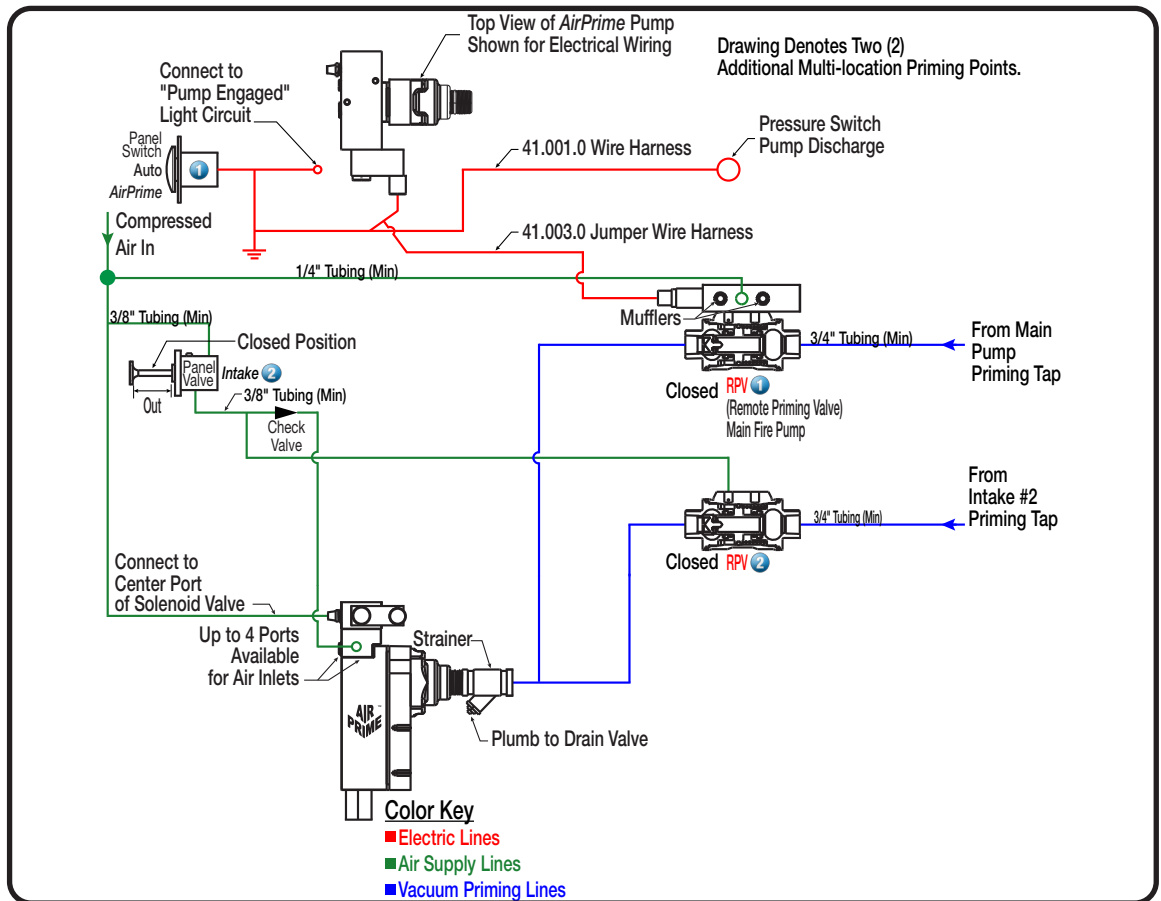

**Figure 3 Multi-Location Auto AirPrime**

### Installation Instructions

1. Locate the existing Manual *AirPrime* unit within pump enclosure. It can be found by tracing the existing air line from any of the primer push-button controls on the pump panel to the TOP of the *AirPrime* unit (See **Figure #1**). Verify that the unit is already mounted ABOVE the highest priming point in suction piping, if not move it higher.
2. Remove the existing airlines and tubing fittings located on the top of the *AirPrime* unit.
3. Attach the new solenoid and manifold assembly (See **Figure #2**) to the top of the *AirPrime* unit using the screws provided. A blue thread-locker material should be used on screws. Be sure to include the o-ring seal provided between the manifold and *AirPrime* unit body. **Note:** This is shipped assembled and must be taken apart prior to installation on your primer. Reassemble using all contained parts. Ensure that the three (3) ports in the solenoid are above the two (2) manifold ports as shown in **Figure #9**.
4. Reconnect the air line from the PUMP panel push-button to the center port of the solenoid just added (See **Figure 3**). Connect the additional air line(s) from the other panel push-button(s) to the 1/4" NPT ports in the manifold below the solenoid. Plug any unused ports in the manifold.
5. Locate the existing Remote Priming Valve {RPV} actuated by the push-button control for the PUMP. Remove the tube fitting and airline at the top of this RPV. Attach the new solenoid provided to the top of the existing PUMP RPV. (**NOTE:** The wire end of the solenoid should be at the "arrow head" end of the RPV as shown in **Figure 3**). Use the screws provided with some blue thread locker. Reconnect the air line to the center port of this solenoid. Plug remaining side 1/8" NPT port with included plug.
6. Remove the existing PUMP push-button control valve on the pump panel. Disconnect existing Air-in and Air-out airlines and fittings from push-button valve. Next, connect the Air-In and Air-Out air lines (Just removed) together, and wire tie them out of the way from the opening in the control panel.
7. Replace the existing PUMP push-button with the new rocker switch control provided on pump panel (See **Figure #2**). The existing hole in the panel will have to be made rectangular as shown in **Figure #4**.
8. Install the pump pressure switch provided in a 1/4" NPT "Discharge Pressure" opening on the top of the fire pump. Verify that the pump pressure switch is in a vertical orientation and in a position that allows for proper draining (See **Figure #5**).
9. Install the Automatic *AirPrime* wiring harness as follows: (See **Figures 6, 7, 8**).
  - 9a Gray 5-prong plug to rocker switch control in pump panel bezel, and connect 6" pigtail to wiring harness (gray plug).
  - 9b White wire to "OK TO PUMP" light circuit or to fire pump shift control circuit (PTO or split shaft) (1 1/2 feet long) [.5 m].
  - 9c Red (+) and black (-) wires to power supply (1 foot long) (Wiring and 1 amp fuse by installer).
  - 9d Plug-in the single end of the Jumper Wire Harness (See **Figure 3**) to the solenoid valve added to the top of the Pump RPV. Plug other ends of jumper to 9d (below) and to solenoid added to the top of priming unit (See **Figure 3**).
  - 9e Plug in to fire pump discharge pressure switch (5 feet of cable) [1.8 m] (See **Figures 5 and 6**).

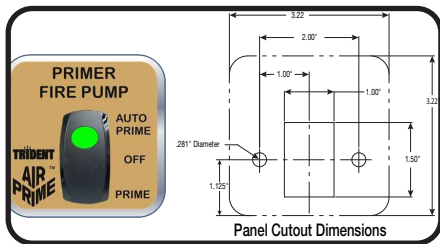

**Figure 4**



**Figure 5**



**Figure 6**

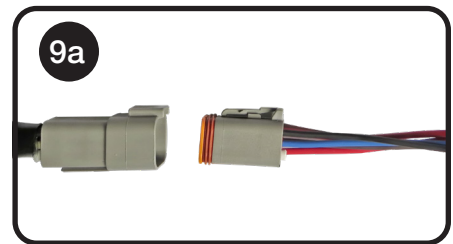

**Figure 7**

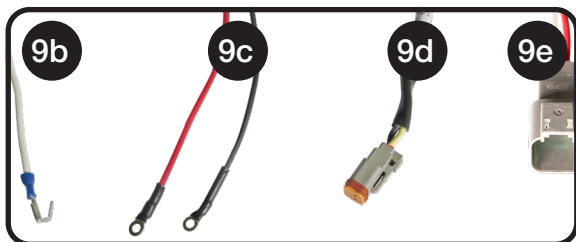

**Figure 8**

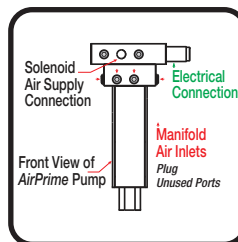

**Figure 9**